

**These installation instructions are for informational purposes only. Phase 5 recommends all installations be done by a qualified gunsmith.**

The installation procedure for all the Phase 5 LPSN rails is the same regardless of length and style with the only difference being the screws included (and the Allen wrenches required)

Included:

- LPSN rail
- Barrel Nut
- Mounting Screws

Tools required:

- Torque wrench
- [1-1/8" slim profile crowfoot wrench](#) (max .499" head thickness)
- Vise
- Sturdy upper receiver vise block or barrel extension torque rod
- 3/32" (and 5/32" for some models) Allen wrench(s)
- Anti-Seize lubricant
- Safety glasses

Before starting the installation process, make sure to follow all basic safety rules and make sure the weapon is clear of any magazines or ammunition. Clear your workspace of any unneeded clutter and wear safety glasses. If you are replacing an existing hand guard, you'll need to disassemble the upper receiver before proceeding.

- 1) Insert the barrel into the upper receiver and insert onto a barrel extension torque rod clamped in a vise, or clamp the upper and vise block securely in the vise

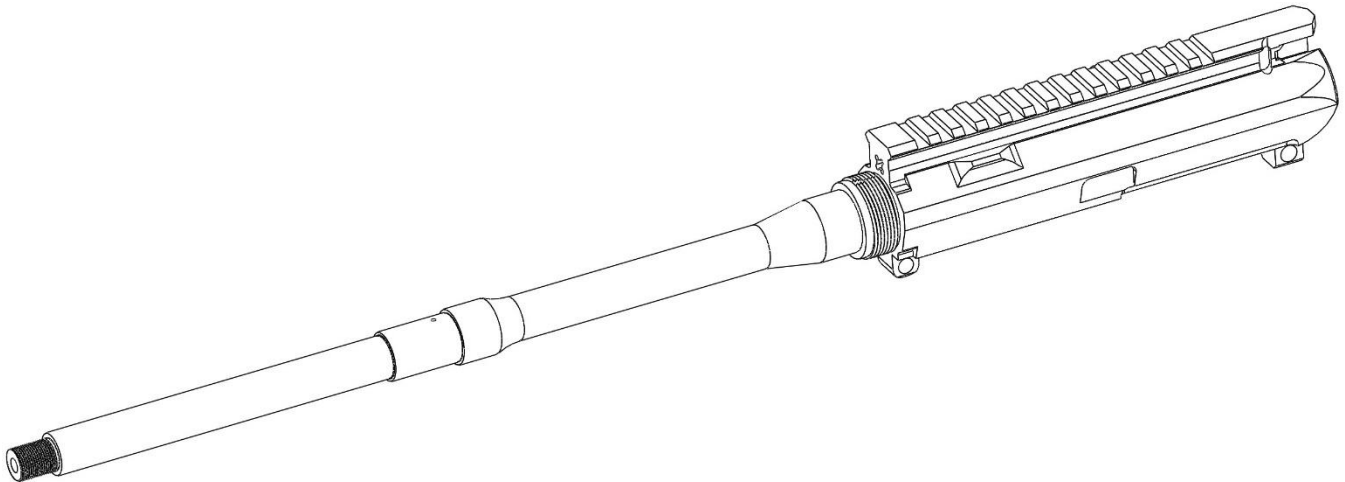

- 2) Apply a small amount of anti-seize lubricant to the upper receiver threads to protect them.

- 3) With the upper receiver secured, install the barrel nut hand tight, then use the torque wrench and torque the barrel nut to 35 ft.-lbs. Next, loosen and re-torque the barrel nut past 35 ft.-lbs. till the next threaded hole is in line with the gas tube hole in the upper receiver at 12 o'clock, but not to exceed 80 ft.-lbs. This may require loosening and re-torquing to achieve the proper alignment.

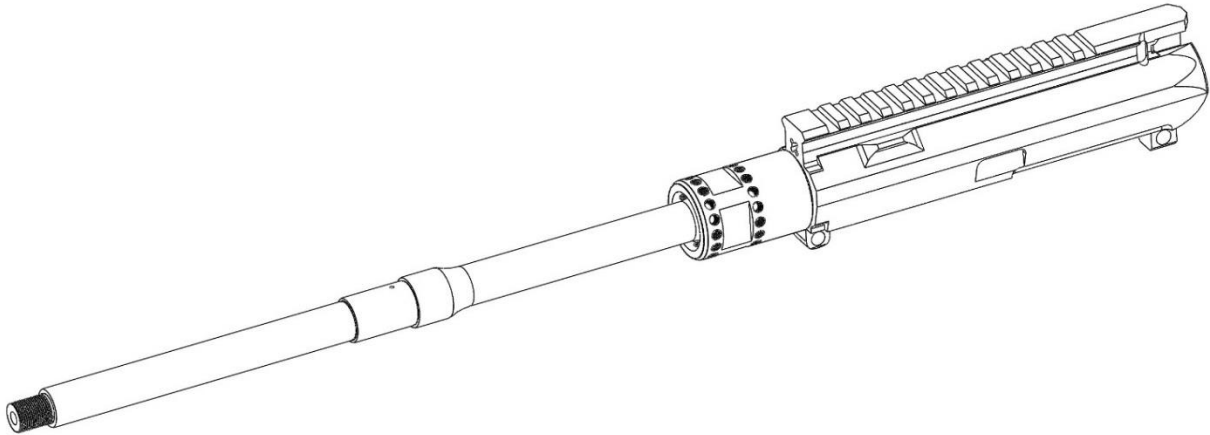

- 4) Install your low profile gas block and gas tube

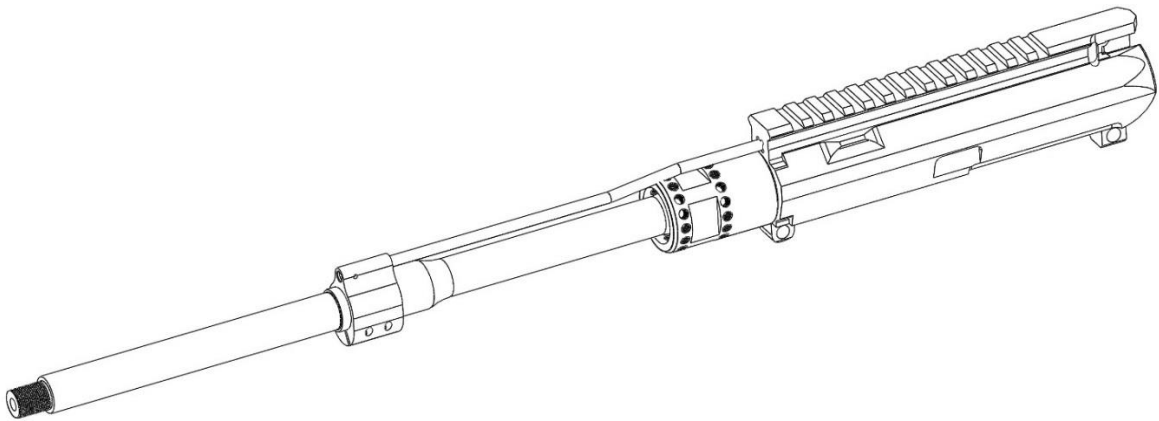

- 5) (Optional) Install your muzzle device. This can also be done after the rail install is completed depending on the barrel's length

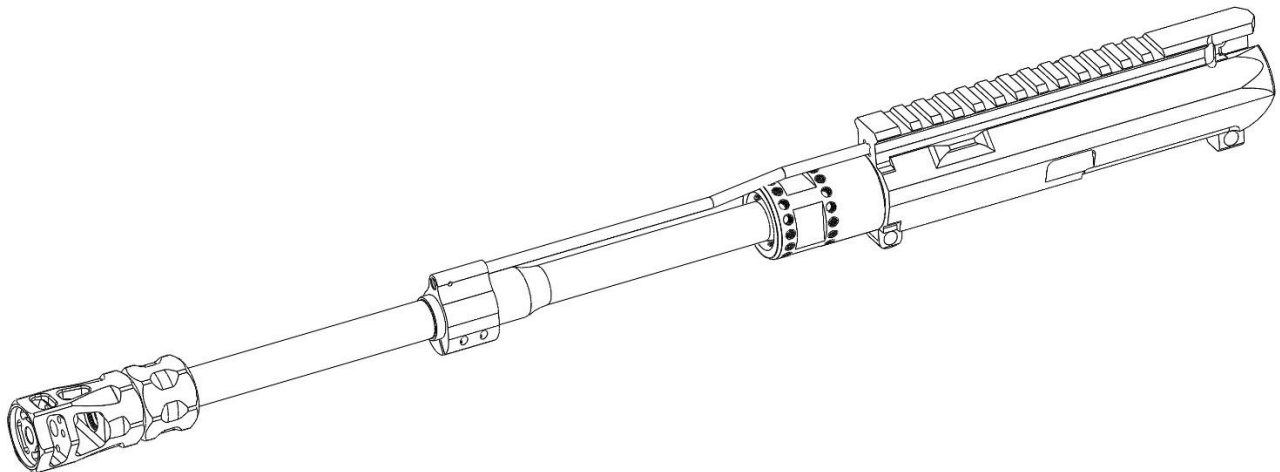

- 6) Slide the rail over the barrel, gas block and tube all the way to the upper receiver and verify that the barrel nut is in the correct position

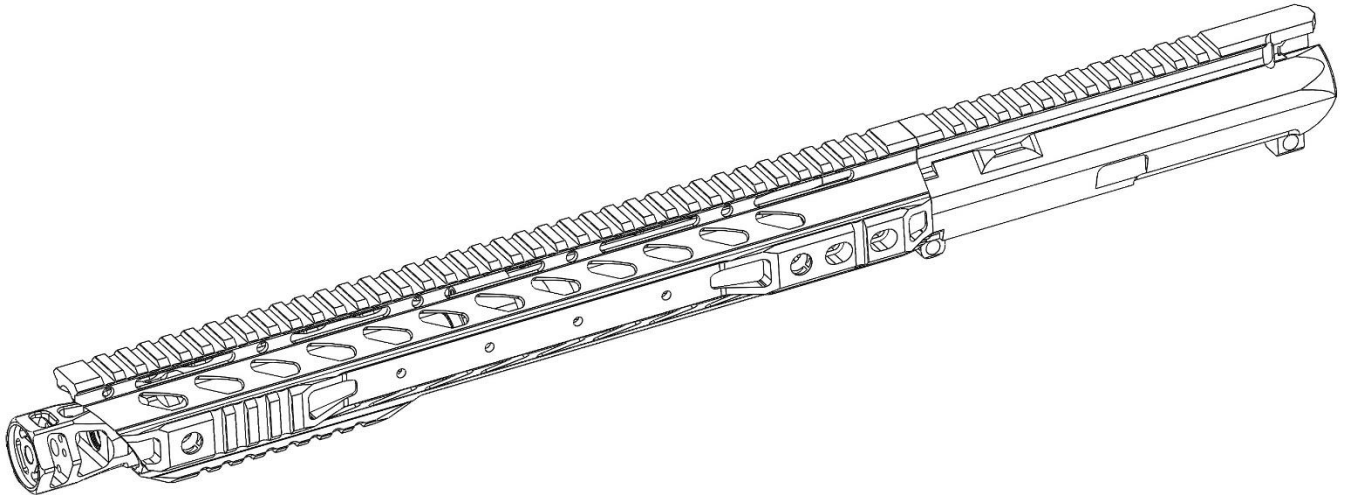

- 7) Loosely install the six socket head cap screws. If your rail has two screw types, the low-profile cap screws will go in the 6 o'clock position. The low head cap screws use a 3/32" Allen wrench, and the standard socket head cap screws use a 5/32" Allen wrench.

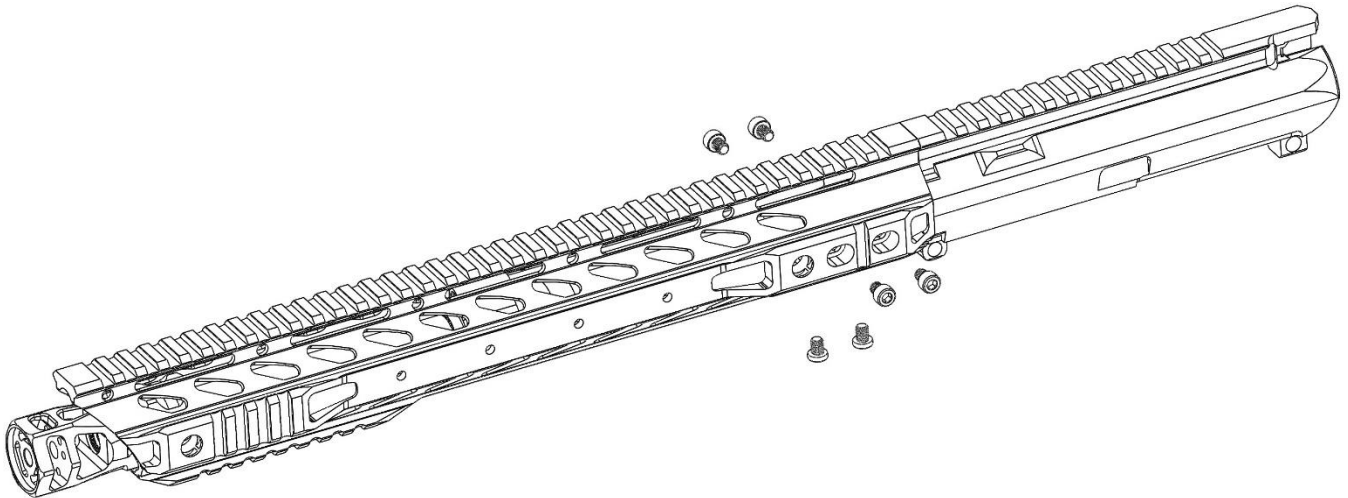

- 8) Secure the four Allen screws at the 3 and 9 o'clock positions to 25 to 30 in.-lbs. (INCH, not FOOT) starting with the rear screws and alternating between the sides
- 9) Torque the bottom (6 o'clock position) screws to 25 to 30 in.-lbs. (INCH, not FOOT)